



ART SELECTION ADVISORY COMMITTEE
Friday, August 10, 2012 1:00 PM – 3:00 PM
City of Fairbanks, City Hall, 800 Cushman Street
FMATS Conference Room

1. Call to Order
2. Introduction of Members, Staff and Attendees
3. Public Comment Period
4. Approval of the August 10, 2012 Agenda
5. Approval of the July 24, 2012 Meeting Summary
6. New Business
7. Old Business
 - a. Request for Qualifications and Concepts Questions and Answers
 - b. Review Draft Selection Process
8. Public Comment Period
9. Other Issues
10. Adjourn

Next Meeting: August 13, 2012 at Noon (Teleconference with Artists)

FMATS Art Selection Advisory Committee
Meeting Summary
July 24, 2012
Fairbanks City Hall, City Council Chambers

IN ATTENDANCE: *FMATS Art Selection Advisory Committee Member **FMATS Staff

*Donna Gardino, FMATS (Chair)
*Sue Sprinkle, Graphic Designer (absent)
*Mark Fejes, Community Artist
*Kelley Hegarty-Lammers, Chena Riverfront Commission
*George Lounsbury, Pioneers of Alaska
*Amy Nordrum, Fairbanks Downtown Association
*Carole-Ann Newcomer, Doyon (absent)
*Julie Engfer, Festival Fairbanks
*June Rogers, Fairbanks Arts Association (absent)
*Ron Inouye, Historian, Community Member (absent)
** Jessica Smith, FMATS
**Kellen Spillman, FNSB

1. Call to Order

Chair Donna Gardino called the meeting to order at 2:03 pm.

2. Introduction of Members, Staff and Attendees

The members of the FMATS Art Selection Advisory Committee and members of the public introduced themselves.

3. Public Comment Period

There were no public comments.

4. Approval of the July 24, 2012 Meeting Agenda

- **Motion:** To approve the July 24, 2012 Meeting Agenda. (Nordrum, Engfer)
- **Vote on the motion:** None opposed. Approved.

5. Approval of the June 28, 2012 Meeting Summary:

- **Motion:** To approve the June 28, 2012 Meeting Summary. (Engfer, Nordrum)
- **Vote on the motion:** None opposed. Approved.

6. Approval of the July 12, 2012 Meeting Summary

- **Motion:** To approve the July 12, 2012 Meeting Summary, with changes. (Engfer, Hegarty-Lammers)
- **Discussion:** Ms. Engfer said that the last paragraph of page two reads “members of the explained the definition of the term” and she noted that the group should be identified in which the members belong. Ms. Engfer said that in the same paragraph, where it talks about a power utility and a power supply, it did not make much sense to her. Ms. Engfer said that the bottom of page three Mr. Fejes is referred to as Ms. Fejes. Ms. Smith said that she also incorporated any corrections that were e-mailed to her.
- **Vote on the motion:** None opposed. Approved.

7. New Business

There was no new business

8. Old Business

a. Request for Qualifications and Comments

Ms. Gardino said that FMATS has incorporated the comments that were received into the RFQ and a recent draft is available in the meeting packet. Ms. Gardino said that she did not incorporate the comments regarding the theme into the RFQ, because the Committee decided that it did not need to be amended. Ms. Gardino said that the schedule was adjusted, with a final approval date of November 21, 2012, which is a FMATS Policy Committee Meeting. Ms. Gardino said that she is planning on releasing the RFQ on July 25, 2012.

Ms. Smith said that she incorporated a few changes including making the word “subartic” one word, updating the schedule, incorporating lifespan into the design section, and rearranging the design considerations.

Ms. Gardino said that in conversations with Jocelyn Young at the Municipality of Anchorage, she emphasized that the lifespan should be incorporated into the RFQ. Ms. Gardino said that Ms. Young thought that 30 – 40 years would be an acceptable lifespan for the project, which was incorporated into page six of the RFQ. Ms. Gardino said that some of the wording regarding power supply and climate extremes was also changed based on Committee comments.

Ms. Gardino said that Ms. Young suggested having the artists submit their questions prior to the pre-submission conference, so that there is time to review the questions. Ms. Gardino said that there also should be a written record of the questions that can be posted on the website. Ms. Gardino said that this is reflected in page seven of the RFQ, which asks for questions to be submitted by August 8, 2012. Ms. Engfer emphasized allowing them to ask follow-up questions.

Ms. Gardino said that the process of posting questions and answers on the website was recommended by Kes and the Art Selection Advisory Committee agreed. Ms. Gardino said that Mr. Schumate will also be present at the August 13, 2012 teleconference to answer any procurement questions. Ms. Gardino said that she asked Ms. Young if it was necessary to have an engineer present at the questions session and that Ms. Young believed that it was too premature.

Ms. Hegarty-Lammers said that given the climate in Fairbanks she feels that it would be beneficial to have an engineer present at the initial questions teleconference. Ms. Gardino said that it would be possible to have an engineer present at the meeting.

Ms. Nordrum asked if it would be possible to ask questions, which have not previously been asked, at the August 13, 2012 teleconference. Ms. Gardino said that the artists could ask questions, but the questions will have to be transcribed and put on the website. Ms. Gardino said that she feels that it would be appropriate to answer the very clear cut questions during the teleconference, but some questions might need to be tabled for discussion.

The Committee agreed that August 8, 2012 would be an appropriate date to have the questions due to the Project Manager.

Mr. Fejes said that he would like to see an Art Selection Advisory Committee meeting schedule compared to the dates listed in the RFQ, because he is concerned that there will not be enough time to meet.

The Committee discussed some technical edits to the RFQ including the following:

- Page 4 of 20 – Selection, Criteria, and Process – Should not capitalize the sub-headings under this section.
- Page 7 of 20 – Schedules and Deliverables – Should not capitalize the sub-headings under this section.
- Entire Document – Word “greenspace” and “green space” should be consistent
- Page 6 of 20 – Lifespan – should be no period after “30 – 40 years.”
- CAFÉ Preview – “Theme” is missing
- Page 4 of 20 – Under Downtown Fairbanks – Word “interior” should be capitalized

Mr. Fejes asked if anyone else wanted to rehash the theme, possibly to remove the first sentence. The Committee agreed that they would not like to rehash the theme.

b. CAFÉ

Ms. Gardino said that the RFQ is still scheduled to be published on July 25, 2012, including the technical edits made at the meeting.

c. Questions

Ms. Gardino said that the questions will be due to FMATS by August 8, 2012 and will be published on the website, along with the answers.

Mr. Fejes asked if the RFQ could be changed based on questions that are received from artists. Ms. Gardino said if there is a minor change, it could just be posted online, but if a major change and/or clarification is necessary, an addendum may be required.

d. Historical Plaques – Update

Ms. Gardino said that the FMATS Policy Committee agreed to fund \$10,200 for historical plaques. Ms. Gardino said that it is still possible to work with the FNSB Historical Preservation Commission to include plaques along with other plaques along Illinois Street for the historical district.

Ms. Gardino said that she will get in touch with Melissa Kellner about being included in phase three of the historical sign project. Ms. Hegarty-Lammers said that she thinks that it is important coordinate the FMATS plaques with the Historical Preservation Commission.

Mr. Lounsbury said that he thinks that the plaques in the greenspace should represent the buildings that were in the area, rather than people. Ms. Gardino said that she has received a call requested that Bobby Sheldon be included in the historical plaques. Mr. Lounsbury said that he is concerned that there are too many people that are wanted to be represented in the greenspace.

Mr. Lounsbury and Ms. Engfer said that they could attend some meetings to include some of these ideas. Ms. Gardino said that she would get on the next agenda for the Historical Preservation Commission. Ms. Hegarty-Lammers said that it is important to coordinate on sign material and design.

e. Budget and ICAP

Ms. Gardino said that there is enough funding in the budget to fund up to \$300,000 for the art, stipends up to \$10,000 for up to five finalists, and the Committee has already spent \$7,353.60. Ms. Gardino said that there will not be ICAP charged directly on the funding for the FMATS Art Selection Advisory Committee.

f. National Article

Ms. Nordrum had nothing to report on a national article.

Ms. Gardino said that the RFQ will be advertised through various media including the Americans for the Arts website, Alaska Council for the Arts, list serves through June Rogers and Jocelyn Young, City of Fairbanks Webpage, and the Fairbanks Daily News Miner. Ms. Gardino said that Ms. Young thought that this was a good mix of advertisement.

9. Public Comment Period

There were no public comments.

10. Other issues

a. Next Meeting Day/Time

The Committee agreed that they would meet again on August 10, 2012 at 1:00 pm to discuss the questions, which are due August 8, 2012.

Ms. Smith said that she would like to have a training session for the Committee Members on CAFÉ prior to each Committee Member scoring the projects. Ms. Gardino said that she thought that it would be inappropriate for Committee Members to review projects prior to the August 27, 2012

proposal deadline. The Committee agreed to hold a training session on CaFÉ on August 28, 2012 at 2:00 pm. Ms. Gardino emphasized that this is not a chance for the Committee Members to review projects together, but just to become familiar with the CaFÉ interface.

Ms. Hegarty-Lammers said that she feels that it is very important to have an engineer and Mr. Shumate present at the August 10, 2012 meeting.

Ms. Gardino said that, according to the schedule, the Committee would like to select finalists by September 17, 2012. The Committee agreed to hold a meeting on September 7, 2012 at 1:00 pm to discuss the proposals. Ms. Gardino said that each Committee Member will review the proposals prior to this meeting and come to the meeting with their top five proposals. Ms. Smith asked that the Committee e-mail her each of their top five proposals prior to the meeting. Ms. Gardino said that each Committee Member should select their top five independently and that the Committee Members should not discuss the results until the September 7, 2012 meeting.

Ms. Smith said that the first round of the process will be a “yes”, “no”, “maybe” process, discussed at the previous meeting. Ms. Hegarty-Lammers said that it is very important that the selection process is defensible and should be committed to writing.

There was a discussion about whether or not each Committee Member should rank their top 5. It was decided that there will not be a prioritization and that each Committee Member should just come with their top five projects unranked. Ms. Hegarty-Lammers asked if a reminder e-mail could be sent out with the entire ranking process.

Ms. Gardino said that the September 7, 2012 meeting will be to review each of the projects that have been selected by the Committee Members, possibly up to 45 projects. Mr. Fejes asked that some type of visual be available at the meeting even if that is just a print out.

Ms. Hegarty-Lammers said that the public is likely to attend any meeting, including artists, which is why she feels that it is very important to have a defensible documented decision process. Ms. Gardino said that in the September 7, 2012 meeting the Committee should narrow the applicants down to five or even ten and then use the scoring points to further narrow down the applicants to five at another meeting. Ms. Smith said that after the September 7, 2012 meeting she believes that it would be appropriate to switch from the CAFÉ rating to the FMATS numerical ranking.

Ms. Gardino said that the Committee could then independently score ten projects and hold another meeting to discuss the ten projects and scores, giving each Committee Member an opportunity to change their score.

Ms. Hegarty-Lammers said that in the documented process there needs to be a discussion step, which would be where Committee Members would have a chance to change their scores. Ms. Hegarty-Lammers said that she thinks that the schedule needs to be changed to read that “artist proposals are due” on October 26, 2012. The Committee agreed.

Ms. Gardino said that the Committee has not discussed in detail what the RFP would look like. Ms. Hegarty-Lammers said that she believes that the RFP will be very much defined by what comes

out in the pre-submission teleconference. Ms. Gardino said that there will need to be some type of contractual agreement regarding the RFP because money is going to be given to the artist. Ms. Gardino said that the Committee has not agreed on what the deliverable will be for the RFP, whether it is a model, drawing, video, or some other type of presentation. Mr. Fejes said that it must be clear to the Committee what the artist is proposing and the type of presentation should be left up to the artist.

Ms. Gardino said that the presentation does not have to be face to face, but could be a SKYPE presentation. Mr. Fejes said that he feels that allowances should be made not to let artists view the other artist presentations. Ms. Gardino said that it is a public process. Ms. Hegarty-Lammers said that in her personal consulting background she is never allowed to sit in on another consultant's interview.

Ms. Gardino said that there are still questions that need to be answered regarding how a model will be presented over SKYPE or if a model will be shipped to Fairbanks. Ms. Gardino said that it could be possible to interview the top two applicants. Ms. Gardino said it will probably be best to leave the media up to the artist, to clearly present their case, and she will have the City Attorney write up the language. Ms. Gardino said that she believes that the RFP could be a very short document.

The Committee reviewed future meeting dates, which are as follows:

- August 10, 1:00pm
- August 13, 12:00pm
- August 28, 2:00pm
- September 7, 1:00pm

Mr. Fejes asked if it would be possible to adjust the schedule, if the Committee realized that they did not afford themselves enough time. Ms. Gardino said that the end date could be amended to the December FMATS Policy Committee meeting rather than the November FMATS Policy Committee meeting, but the goal is to complete the process as soon as possible.

11. Adjourn

- **Motion:** Motion to adjourn. (Hegarty-Lammers, Nordrum)
- **Vote on the motion:** None Opposed. The meeting adjourned at 3:19 pm.

Next Art Committee meeting: Friday, August 10, 2012, 1:00 pm at Fairbanks City Hall, FMATS Conference Room.

Approved: _____

Date: _____

Donna Gardino, Chair
FMATS Art Committee

Fairbanks Downtown Greenspace Project
RFQ/C Questions and Answers
August 13, 2012

1. Can an applicant submit more than one concept or application?

The system is set to accept a single application per CaFE artist account. To make an additional application, the artist would need to create/use an additional CaFE artist account. This is not uncommon. The artist profile information may be identical in both accounts. The only piece of information that must be unique is the username (even the passwords can be the same).

2. Has the site landscaping phase of the project been completed or is final grading awaiting the artist proposal?

The final grading design has been completed. See the greenspace landscaping PDF (attached). Any grading changes proposed will need to be reviewed and approved by the State of Alaska Department of Transportation and Public Facilities (DOT & PF).

3. When does the river trail get completed and is there a map of its route?

See the streetscape key plan (attached) for bike path details. The bike path will be complete this September. It connects to Barnette Street approximately 225' north of the bridge. It comes down west of Barnette Street next to the warehouse and goes underneath the Barnette Street and Cushman Street bridges and ends approximately 175' east of the Cushman Street Bridge in Shoreway/Overlook Park.

4. I noticed a culvert emptying into the river. I assume it is surface runoff. What is the "watershed" of this runoff?

This outfall culvert will contain storm water from catch basins just south of Phillips Field Road. A storm trunk line runs through the middle of the triangle and there are two storm water manholes located in the triangle. This is surface runoff into the Chena River Watershed.

5. What does the city have planned for civic events and social engagement for this greenspace?

This site is not under the purview of the City of Fairbanks. No events are planned at this time. The site is located within the State of Alaska Department of Transportation and Public Facilities' right-of-way. Any event would require the need for an encroachment permit from the DOT & PF (see the Alaska Administrative Code [17 AAC 10.011](#)). [17 AAC 05.045](#) would apply regarding the prohibition of commercial activities in this area. [17 AAC 20.015](#) requires highway event permits.

Fairbanks Downtown Greenspace Project
RFQ/C Questions and Answers
August 13, 2012

6. Can the bridge be attached to (i.e. special lighting features)?

The footprint for the artwork is south of the concrete plaza and north of the bike path. The bridge is not in the footprint.

7. Am I correct in thinking you would like proposals that are indicative of the Northern Lights, is that what is meant by "associated phenomenon"?

The committee believes that relating "associated phenomenon" to just the northern lights (aurora borealis) is a very limited view of what makes the Fairbanks environment unique and hesitates to define it for the artist.

8. Are you willing to consider a submission from an Australian sculptor?

Yes. The request for qualifications is open to all.

9. Are there architectural renderings or site specific plans or drawings for the Fairbanks Greenspace Project?

The only site specific plans are contained in the Site Details as provided in the RFQ/C.

10. The FMATS Art Selection Advisory Committee's description of what they would like to see incorporated in the artwork clearly states that the phenomena associated with Fairbanks' location and seasonal and climate patterns are a critical element of the project. The description indicates that the committee is interested in these elements being incorporated in both form *and* function, possibly through the use of interactive components. Due to Fairbanks' weather and temperature extremes, I'm wondering what kind of interactive components you think would survive the Alaskan climate?

The committee leaves that up to the artist who may need to consult an engineer or architect for an answer. The committee understands that the interactive components may only be operational to a certain temperature and the artist may want to provide alternative presentations of the art during the coldest months.

11. Is it necessary that the artwork include interactive parts? Or would an iconic, dynamic work of art that celebrates the natural beauty and climatic phenomena of Fairbanks be equally desirable?

It is not required to include interactive parts. However, the artist should review the evaluation criteria in the RFQ/C.

Fairbanks Downtown Greenspace Project
RFQ/C Questions and Answers
August 13, 2012

12. I read that Fairbanks gets up to 12 feet of snow during the heart of winter. Will the greenspace be plowed so that the artwork will be visible year round? Would an internal heating device be necessary to ensure that snow and ice melt off of the artwork during these cold months?

Fairbanks averages 65 inches of snow typically between October and April or just over five feet. So while it does not snow as much as compared to Anchorage or Valdez, it stays around for the winter due to the extreme cold temperatures.

The greenspace will not be plowed in the winter. Artists are to provide information regarding the maintenance requirements of the art (see page 15 of the RFQ/C). Artist-provided maintenance guidelines will be evaluated and discussed prior to contracting for the art. As power is available, an internal heating device may be considered but will be dependent on the Fairbanks North Star Borough's willingness to fund such maintenance.

13. Does the project include associated landscaping?

The artist will need to be able to work around those plantings shown in the greenspace landscaping pdf (attached). The project can include additional landscaping but maintenance will be a consideration under all circumstances.

14. Are there height and size restrictions?

There are no specific height or size restrictions at this time. However, a specific encroachment permit proposal will need to be approved by DOT & PF. DOT & PF will be reviewing the permit request to see how it may affect maintenance, traffic operations, and future projects such as the reconstruction of the Cushman Street Bridge.

15. Is there power to the site?

Yes. See page 6 of the RFQ/C.

16. Are there local contractors to work with on installation or do we need to bring our own installers, electricians, etc.?

It is up to the artist whether they want to use local contractors or bring their own. The selected artist's budget will include all costs of design, engineering, fabrication, installation, public art transportation, special handling fees, special lighting (if any), photographic documentation, approved site visit, liability and automobile insurance, and an identifying plaque made to City standards and specifications. See page 5 of the RFQ/C

Fairbanks Downtown Greenspace Project
RFQ/C Questions and Answers
August 13, 2012

17. Is shipping a problem and does it take a long time, does it have to go through customs or anything and is the cost by weight, size or both?

Details regarding logistics and transportation are up to the artist to provide and execute. However, the artist should plan ahead since shipping to Fairbanks can be expensive and take some time depending on what is being shipped.

The selected artist's budget will include all costs of design, engineering, fabrication, installation, public art transportation, special handling fees, special lighting (if any), photographic documentation, approved site visit, liability and automobile insurance, and an identifying plaque made to City standards and specifications. See page 5 of the RFQ/C

18. Will the city provide permits, are there extra costs or expenses I need to be aware of?

A beautification permit will be required. See page 6 of the RFQ/C. Other permits may be necessary depending on the art to be installed. An encroachment permit may also be required. See [17 AAC 10.011](#). Any other extra costs are a part of the budget as outlined on page 5 of the RFQ/C.

19. Are there hotel and car rental accommodations close by and how far from the airport is the site for art?

Yes. The site is 5.8 miles from the airport.

20. Is there a hands-on person to work with if any problems arise?

There is a project manager to ensure contract provisions are satisfied. The artist is ultimately responsible for the successful installation of the art and must provide the proper team to successfully complete the contract.

20. Are there times of the year when it's best not to work or transport shipping, etc.?

It is up to the artist and what they are creating to determine the ideal time to work and transport art. The artist should be or become familiar with the logistics of working in a sub-arctic environment.

21. Who will make the decision on the Art, the city council or an Art Committee?

The FMATS Art Selection Advisory Committee will make the selection with final approval by the FMATS Policy Committee.

Fairbanks Downtown Greenspace Project
RFQ/C Questions and Answers
August 13, 2012

22. Is there a preferred placement within the greenspace or is that totally left to our discretion?

It is up to the artist's discretion within the limits as defined on page 5 of the RFQ/C.

23. Is there electricity available now to the area 50' north of the bike path and river?

Yes.

24. Do you have a height restriction or what is the site line?

There are no specific height or size restrictions at this time. However, a specific encroachment permit proposal will need to be approved by DOT & PF. DOT & PF will be reviewing the permit request to see how it may affect maintenance, traffic operations, and future projects such as the reconstruction of the Cushman Street Bridge.

25. Has soil testing been done to the whole area and will it support a concrete pad and bronze sculpture?

Soil testing has been done. The artist must provide the structural fill for the proposed foundation.

26. How wide is the snow removal equipment used in Fairbanks?

The site will not be plowed in the winter. Snow removal may be a necessary maintenance requirement for the installation but will be discussed prior to contracting with the artist. Artists are to provide information regarding the maintenance requirements of the art (see page 15 of the RFQ/C).

27. For the teleconference on the 13th, is there a code number that is entered after the phone number?

No.

28. This RFQ/C is open to all professional artists internationally. Buy America provisions apply. Can you offer practical advice on the implications and legalities of the Buy America Provisions or suggest a person or organization who can?

The Buy America Provisions must apply because the funding stems from the Federal Highway Administration. There are no known waivers of this provision in our region. Please refer to the FHWA statute provided in the link.

Fairbanks Downtown Greenspace Project
RFQ/C Questions and Answers
August 13, 2012

29. Will you consider submissions from an artist team of two which has no past experience installing or developing a realized public art commission, yet has a strong concept?

All submissions will be considered.

30. Because our team has not shared past public art commissions together, will you accept references for the artists as individuals?

Yes.

31. Will you consider submissions which alter the landscape proposed on page 1 of the site details attachment? If so, are there limitations in what can be altered (i.e. grading, planting or incorporating/altering the proposed plaza on the northern end of the greenway)?

Yes, the committee will consider submissions that alter the landscape within limits. The final grading design has been completed. See the greenspace landscaping PDF (attached). Any grading changes proposed will need to be reviewed and approved by the DOT & PF. The plaza cannot be altered.

32. Can you provide a link to the city's standards and specifications?

This term is in reference to the identifying plaque required under section 4 on Page 5. This information will be provided in more detail upon narrowing down the artist concepts to up to five finalists.

33. Due to funding by the Federal Transportation Department, The Davis Bacon Act and weekly certified payroll reports will be required, correct?

Yes.

34. Because the greenspace is not yet fully constructed, is there any possibility to change or amend the construction of the greenspace to accommodate or enhance the art within that contract?

The final grading design has been completed. See the greenspace landscaping PDF (attached). Any grading changes proposed will need to be reviewed and approved by the State of Alaska Department of Transportation and Public Facilities (DOT & PF) and will be a part of the artist's budget for the work.

35. Will a more detailed siteplan (materials, elevations, layout, finishes, etc.) of the greenspace and plaza be provided?

Fairbanks Downtown Greenspace Project
RFQ/C Questions and Answers
August 13, 2012

The final as-built drawings of the space are not expected to be completed in the near-term.

36. What is the level of interaction that the city is looking for? Is this a pedestrian-friendly area, or is the art primarily viewed on a drive-by? Is it seasonal – only in the warmer months, or is the spot active with folks throughout the year?

The committee leaves the level of interaction to be determined by the artist. There is a bicycle/pedestrian path in the greenspace so to that extent the area is pedestrian friendly. There is also the concrete plaza on the north end with sitting walls. This is a newly created space (formerly a parking lot) so how active it will be in the winter remains to be seen.

37. What type of accessibility will this project have during the winter months? (ie. Will the sidewalks be cleared of snow?)

The sidewalks will be cleared in the winter. There is also a bicycle/pedestrian path in the greenspace that will be cleared in the winter.

38. Does the theme of reflecting the cyclic and extreme subarctic climate outweigh your rich history of being a transportation hub?

The theme is as stated in the RFQ/C.

39. We have only begun in-depth research of your seasonal temperatures and arctic light. We have an idea of what you mean by spectacular phenomenon, but are there any examples that you may be envisioning that a work of art might best demonstrate those traits?

The committee would like the artists to envision what might best demonstrate those traits.

40. Does 316L stainless steel have a record of holding up well under Fairbanks weather conditions? What about powder-coated steel?

That is for the artist to determine. This is a sub-arctic desert climate.

41. Is there an issue of frost heave? Does the artwork need to be anchored to bedrock to alleviate this concern? What types of anchors have proved successful in previous commissions?

Fairbanks is in an alluvial plain. In this area, one would typically encounter five feet of silt underlain with about 1,000 feet of gravel. There is no bedrock in the area.

42. Our team of Ingalls/Neubauer has started to into LED and cold cathode lighting that can stand up to extreme temperatures. Are there specific recommendations of proven types or

Fairbanks Downtown Greenspace Project
RFQ/C Questions and Answers
August 13, 2012

brands of readily available extreme weather outdoor LED lighting that can sustain programmed color changes?

LED's work better in colder weather. Under the parent project, the Illinois Street Reconstruction project, there is special lighting for the banner feature. That specification can be found in Addendum #1, section 660-2.01 at <http://www.fmats.alaska.gov/art.shtml>.

LANDSCAPE NOTES

1. ALL PLANTS ARE NURSERY GROWN UNLESS OTHERWISE APPROVED BY ENGINEER.
2. PLANTING BEDS SHALL BE EXCAVATED TO A DEPTH OF 10", AND RECEIVE 12" TOPSOIL AND PLANTING MIX. TOP DRESS PLANTING BEDS WITH 3" SHREDDED BARK MULCH.
3. PLANT MIX TO BE AS FOLLOWS: 40 LBS. OF DRIED CHICKEN MANURE, 3.8 CU. FT. PROFESSIONAL GRADE SPHAGNUM PEAT MOSS, AND 10 LBS. 16-16-16 FERTILIZER PER 100 SQ. FT. OF PLANTING BED, MIXED THOROUGHLY INTO TOPSOIL.
4. LANDSCAPE EDGING TO SEPARATE ALL PLANTING BEDS FROM LAWN AREAS.
5. REFER TO SHEET 8.19D FOR PLANTING DETAILS.
6. REFER TO SPECIFICATION SECTION 618 FOR SEEDING INFORMATION, AND SECTION 621 FOR PLANTING TREES AND SHRUBS.

PLANTING SCHEDULE

QTY	KEY	LATIN NAME	COMMON NAME	SIZE	NOTES
12	BP2	BETULA PAPIRIFERA	WHITE BIRCH	2" CAL.	12" MIN. B&B, FULL & SYMMETRIC HEADS, MATCHING
9	PG10	PICEA GLAUCA	WHITE SPRUCE	10' HT.	B&B, FULL & SYMMETRIC HEADS, MATCHING
3	PC8	PICEA GLAUCA	WHITE SPRUCE	8' HT.	B&B, FULL & SYMMETRIC HEADS, MATCHING
7	M88	MALUS BACCATA	SIBERIAN CRABAPPLE	8' HT.	B&B, FULL & SYMMETRIC HEADS, MATCHING
0	AG4	ACER GINNALA	CLUMP AMUR MAPLE	4' HT.	B&B OR CONTAINER, FULL HEADS
0	CL36	COTONEASTER LUCIDUS	HEDGE COTONEASTER	36" HT.	B&B OR CONTAINER, FULL HEADS
0	RN30	RIBES NIGRUM	BLACK CURRANT	30" HT.	B&B OR CONTAINER, FULL HEADS
0	RR30	ROSA RUGOSA	MIXED RUGOSA ROSES	30" HT.	CONTAINER, MIX RED & WHITE VARIETIES 50/50
0	RG24	ROSA GLAUCA	RED LEAF ROSE	24" HT.	CONTAINER, FULL HEAD
0	SG24	SPIREA X B. 'GOLDFLAME'	GOLDFLAME SPIREA	24" HT.	CONTAINER, FULL HEAD
0	SF24	SPIREA X B. 'FROBELI'	FROBEL SPIREA	24" HT.	CONTAINER, FULL HEAD
0	PF24	POTENTILLA F. 'GOLD DROP'	GOLD DROP POTENTILLA	24" HT.	CONTAINER, FULL HEAD
12	PL	PAEONIA LACTIFLORA	MIXED PEONY	2 GALLON	CONTAINER, MINIMUM 3RD YEAR PLANT
0	PP	PHALARIS PICTA	SWITCH GRASS	2 GALLON	CONTAINER, MINIMUM 3RD YEAR PLANT
12	MY	HEMEROCALIS 'STELLA D'ORO'	STELLA D'ORO DAYLILY	1 GALLON	CONTAINER, MINIMUM 3RD YEAR PLANT
12	DE	DELPHINIUM E. 'BLUE ELF'	BLUE ELF DELPHINIUM	1 GALLON	CONTAINER, MINIMUM 3RD YEAR PLANT
12	TP	TROLLIUS PUMILUS	YELLOW/ ORANGE TROLLIUS	1 GALLON	CONTAINER, MINIMUM 3RD YEAR PLANT
12	IS	IRIS SIBERICA	SIBERIAN IRIS	1 GALLON	CONTAINER, MINIMUM 3RD YEAR PLANT

STATE	PROJECT DESCRIPTION	YEAR	SHEET NO.	SECTION TOTAL
ALASKA	EBL-STP-F-M-0663(4)/63102	2008	8.06D	26

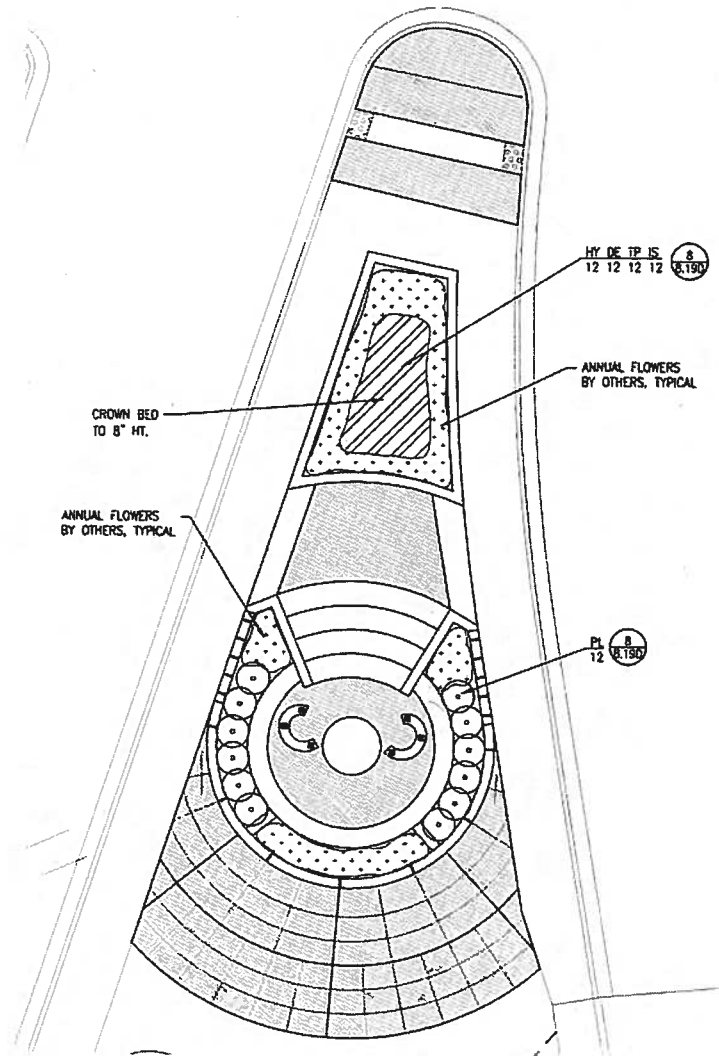

2 GATEWAY AREA PLANTING PLAN
8.06D

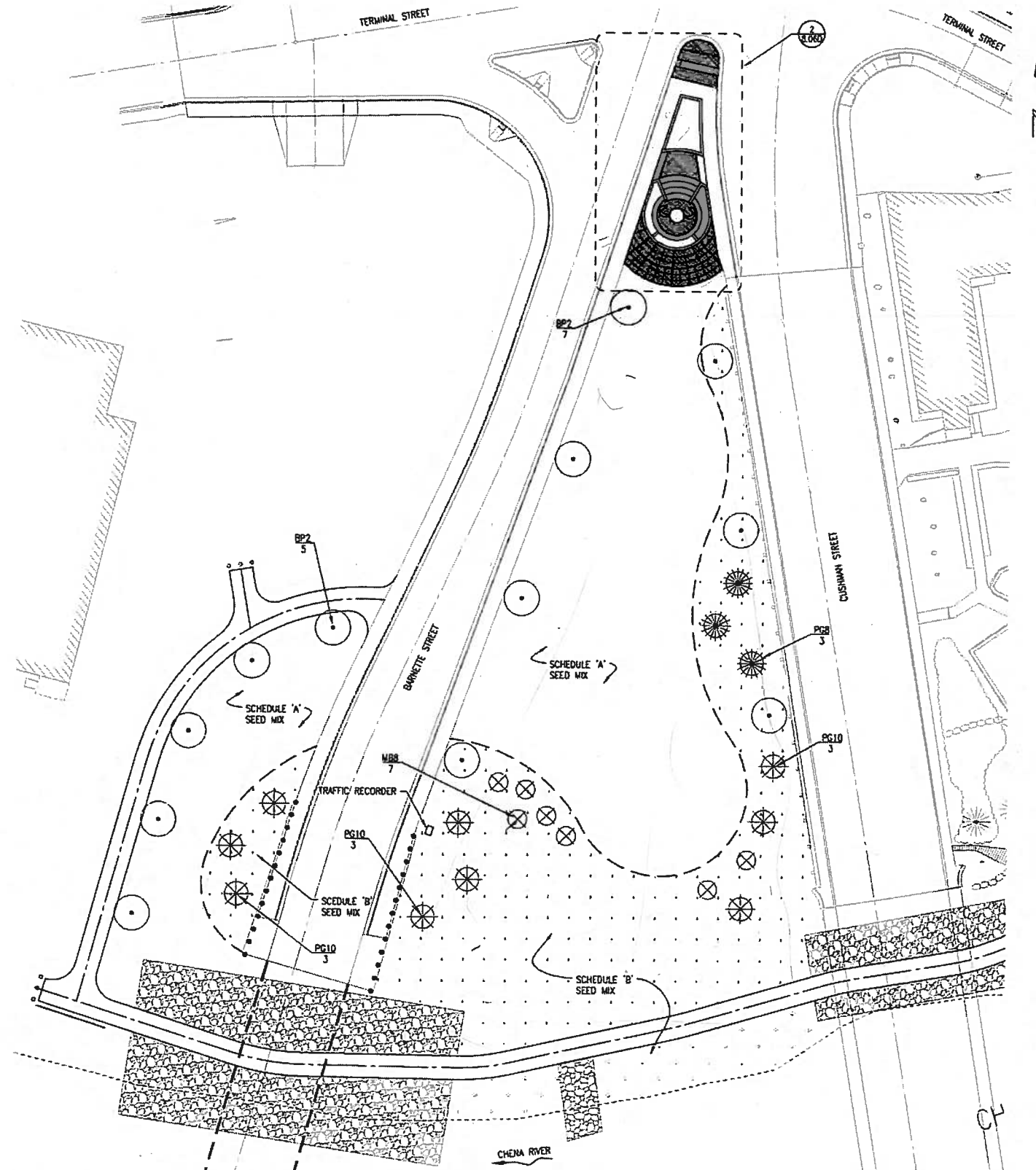

1 TRIANGLE PARK PLANTING PLAN
8.06D

Thursday, June 30, 2011 12:40:55 PM P:\041102\C\ACAD\08.06D.dwg

**ILLINOIS-BARNETTE STREETS
TRIANGLE PARK PLANTING**

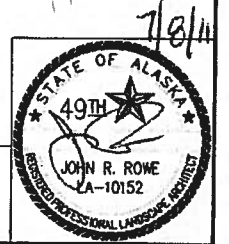

STATE	PROJECT DESCRIPTION	YEAR	SHEET NO.	SECTION TOTAL
ALASKA	EBL-STP-F-M-0663(4)/63102	2008	8.01D	26

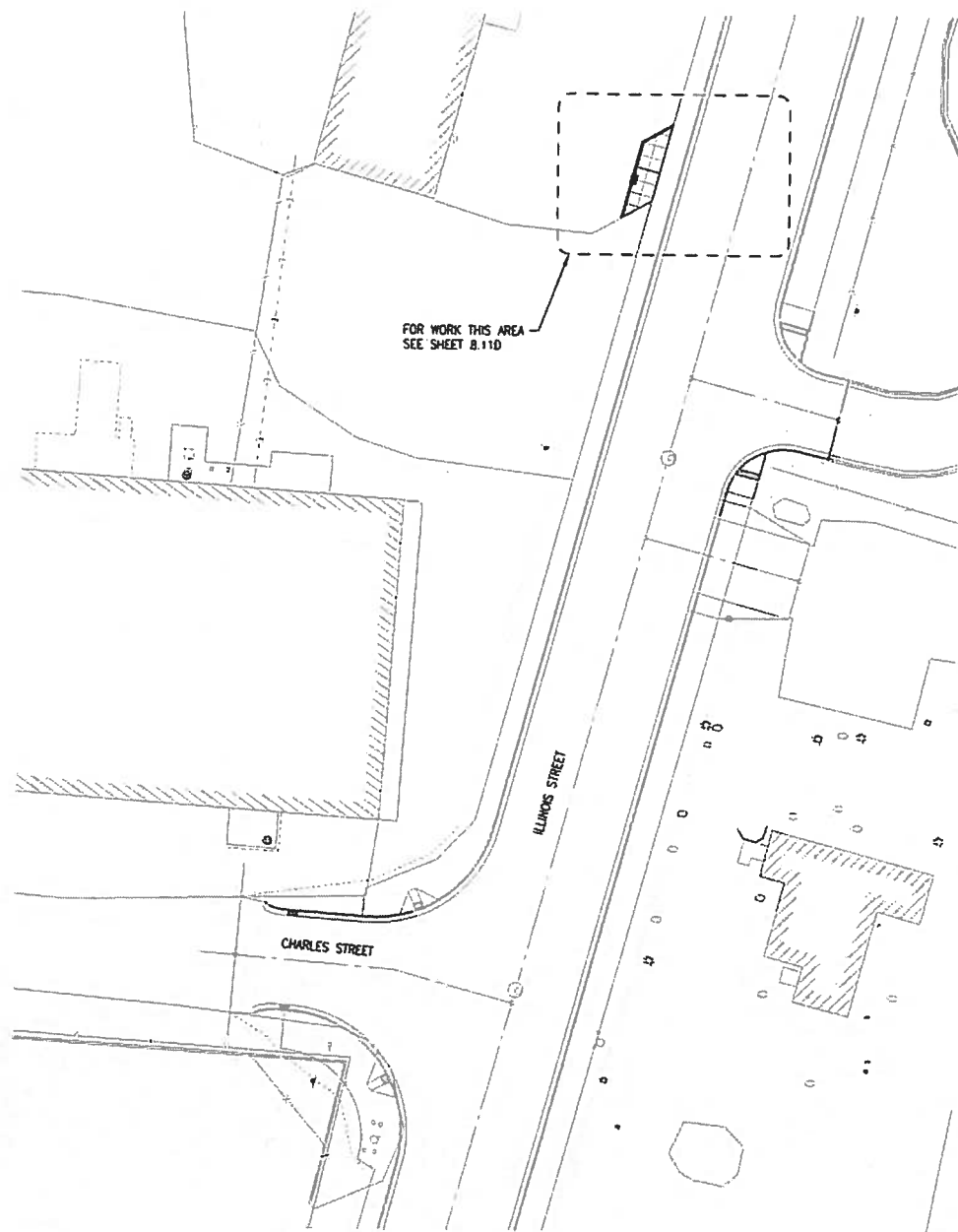

2 ILLINOIS STREET HISTORICAL SITE MARKER VICINITY MAP AND KEY PLAN
8.01D

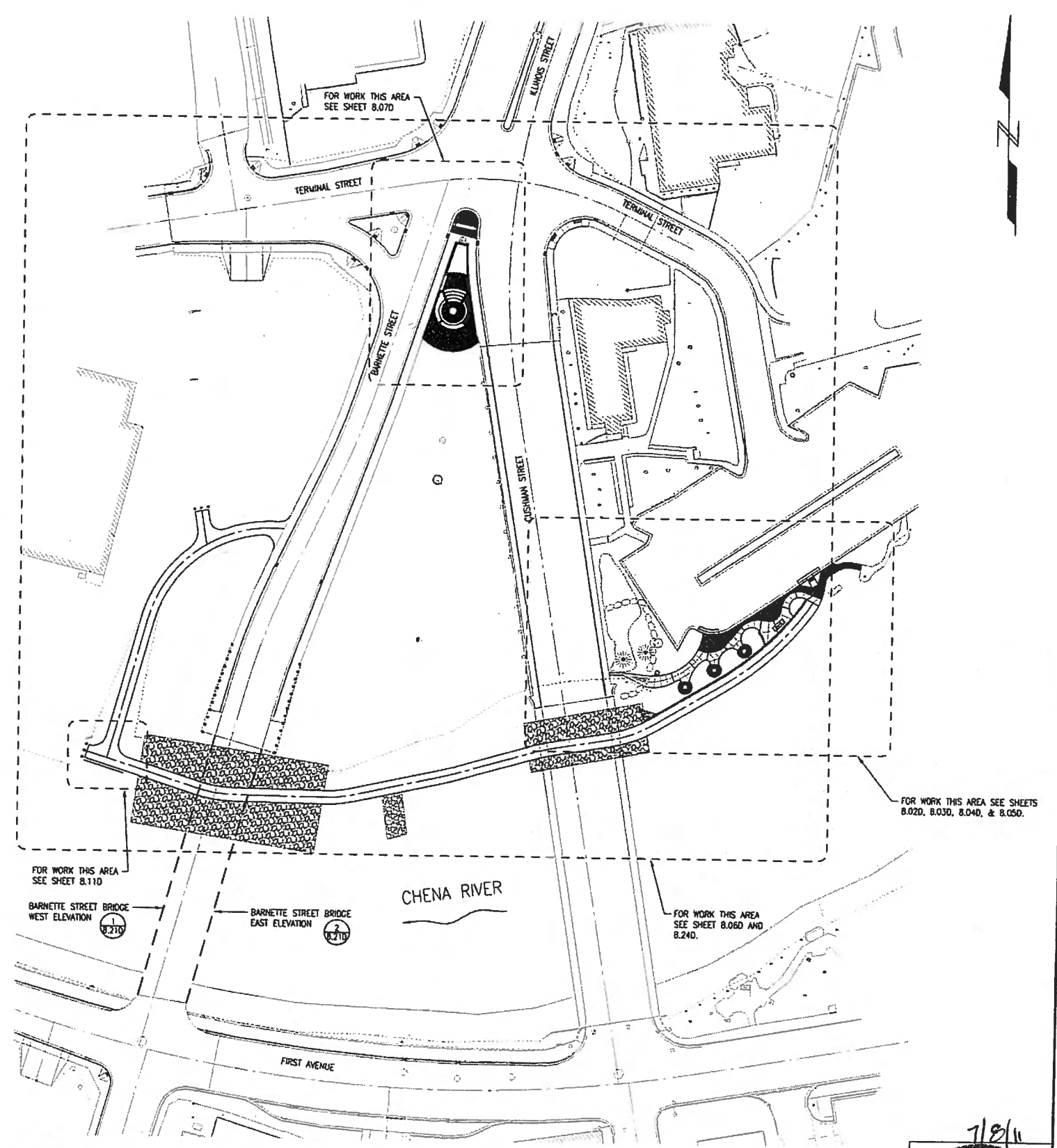

1 ILLINOIS-CUSHMAN STREETS VICINITY MAP AND KEY PLAN
8.01D

**ILLINOIS-BARNETTE STREETS
STREETSCAPE KEY PLAN**

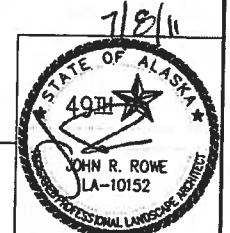

Thursday, June 30, 2011 12:15:47 PM P:\041102\CACAD\C8.01D.dwg

FMATS Art Selection Advisory Committee Selection Process

Draft July 30, 2012

The FMATS Art Selection Advisory Committee (Committee) has developed a process for issuing and reviewing the proposals received for the Call For Entry released on July 25, 2012. This process will document the process of the selection of an artist/team of artists to develop the public art in the greenspace located in downtown Fairbanks. The Call for Entry was released on July 25, 2012 and contained the following schedule (estimated):

Item	Completion Date
RFQ/C Released	July 25, 2012
Questions/Comments Due to Project Manager	August 8, 2012
Pre-submission Teleconference	August 13, 2012
RFQ/C Responses Due	August 27, 2012
Finalists Selected	September 17, 2012
Artist(s) Proposals Due	October 27, 2012
Public Art Selection & FMATS Final Approval	November 21, 2012
Contract Negotiations & Execution	December 14, 2012
Public Art Installed	September 1, 2014

To achieve this schedule, the Committee proposes the following tasks:

Committee Meeting to Discuss Questions Received and to Review Draft Responses to the Questions and Finalize Process

Meeting Date: August 10, 2012
Meeting Location: FMATS Conference Room
Meeting Time: 1 pm – 3 pm

Support to attend: Procurement and engineering experts from the City of Fairbanks.

Pre-Submission Teleconference

Meeting Date: August 13, 2012
Meeting Location: City Council Chambers
Meeting Time: Noon – 2:00 pm

Juror Training – One hour training on how to score (yes, no, maybe) responses

Meeting Date: August 28, 2012
Meeting Location: FMATS Conference Room
Meeting Time: 2:00 pm – 3:00 pm

FMATS Art Selection Advisory Committee Selection Process

Draft July 30, 2012

Juror Independent Review of Responses to the Call for Entry

Time: August 28 – September 6, 2012

Note: This is the initial review of the responses and should be conducted independently with no discussion amongst the jurors regarding any of the entries. Each juror should be prepared to select their top five entries and submit them to FMATS' staff by the end of the day on September 6, 2012. There is no prioritization of the entries by the individual jurors at this time. The time frame for completion of this task may change due to the number of proposals received. A reminder of the deadline will be sent to all two days prior to the deadline.

Committee Meeting to Review Every Juror's Top Five Selections and to Finalize the Draft RFP to include more detailed criteria

Meeting Date: September 7, 2012
Meeting Location: FMATS Conference Room
Meeting Time: 1:00 pm – 4:00 pm

Note: Up to forty-five selections will be independently reviewed by each juror with the concept images all compiled on several pages. After a thirty minute review, each juror will place up to five dots on their most preferred images. A juror may place more than one dot on an image, but is limited to only five dots. Up to ten images with dots will be selected for numerical scoring as detailed in the selection criteria. The scores must be entered into CaFE by September 13.

Scoring may not occur if, after completion of the exercise, there is clearly a top five list of finalists as agreed by the committee.

Committee Meeting to Discuss the Scoring Results and to Select up to Five Finalists

Meeting Date: September 17, 2012
Meeting Location: FMATS Conference Room
Meeting Time: Noon – 2:00 PM

Note: This meeting will be to discuss the final scores of up to the top ten proposals and to select up to five finalists.

RFP to be released to up to five finalists for more developed concepts – September 18, 2012

Set up Committee Meeting to review final proposals and select artist – October 30, 2012

Contact Selected Artist and return proposals to artists not selected

FMATS Art Selection Advisory Committee Selection Process

Draft July 30, 2012

Process stipends to all finalists upon receipt of the submittals

Contact Risk Manager, FNSB Parks and Recreation and DOT & PF and set up Public Meeting for Safety and Maintenance – November 6, 2012

Obtain Final Approval from the Art Committee and FMATS' Policy Committee – November 21, 2012

Draft and execute the Contract with the Artist